

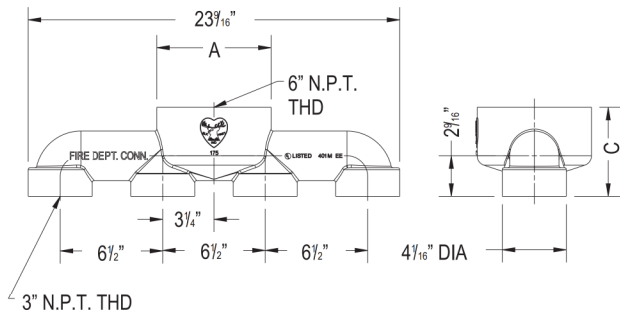

BODY SUB-ASSEMBLIES

4-WAY STRAIGHT MANIFOLD



PRODUCT INFORMATION	MODELS
	710
Size (Inches)	6" x (4) 3"
Escutcheon opening size (Inches)	4 1/4"
Dimension A (Inches)	7 1/4"
Dimension C (Inches)	5 5/8"
Material	Cast Brass
Elkhart products used in	782, 783, 784, 785
Additional uses	With Elkhart's 720 Clapper Snoot (without nipples) as an exposed inlet connection
Weight (Lbs.)	28 1/2"
PSI (BAR)	175 (12.1)
Certifications	U.L. Listed

4-WAY 90° MANIFOLD

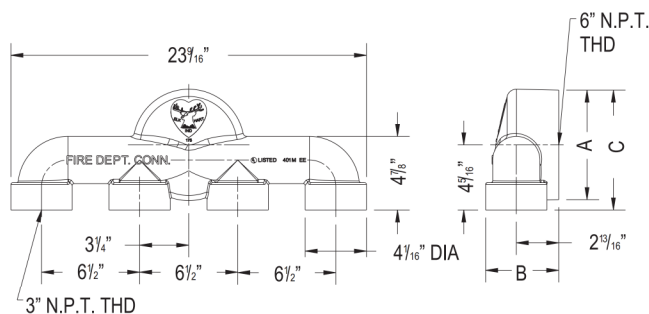

PRODUCT INFORMATION	MODELS
	711
Size (Inches)	6" x (4) 3"
Escutcheon opening size (Inches)	4 1/4"
Dimension A (Inches)	7 1/4"
Dimension B (Inches)	4 13/16"
Dimension C (Inches)	7 15/16"
Material	Cast Brass
Elkhart products used in	780, 781, 786, 787
Additional uses	With Elkhart's 720 Clapper Snoot (without nipples) as either a side walk intake connection or an exposed dry standpipe inlet connection
Weight (Lbs.)	28"
PSI (BAR)	175 (12.1)
Certifications	U.L. Listed

MALE CLAPPER SNOOT

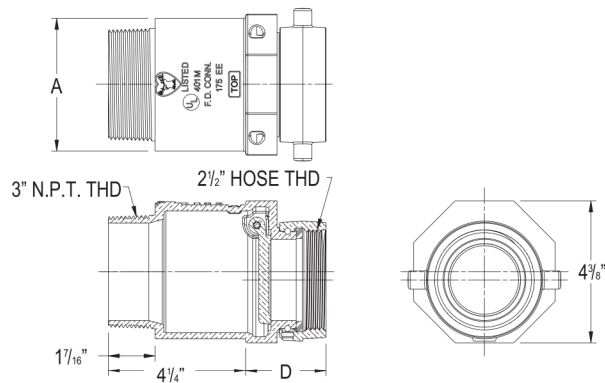

PRODUCT INFORMATION	MODELS
	720
Openings (Inches)	3" M x 2.5" F
Dimension A (Inches)	4 1/4"
Dimension D (Inches)	2 1/2"
Material/Finish	Cast brass with polished brass exposed parts (optional chrome plated available)
Additional uses	Single fire department connection (plug and chain available separately)
Weight (Lbs.)	9 1/2"
PSI (BAR)	175 (12.1)
Certifications	U.L. Listed

FEMALE CLAPPER SNOOT

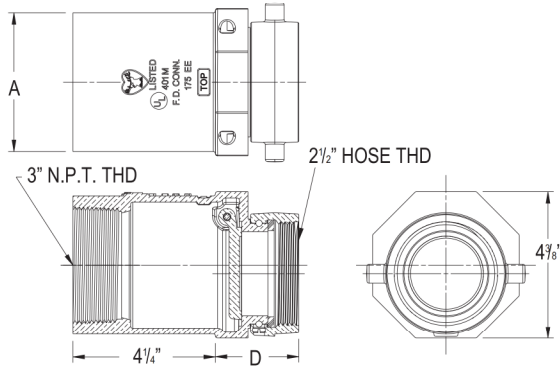

721

PRODUCT INFORMATION	MODELS
	721
Size (Inches)	3" F x 2.5" F
Dimension A (Inches)	4 1/8"
Dimension D (Inches)	2 1/2"
Material/Finish	Cast brass with polished brass exposed parts (optional chrome plated available)
Elkhart products used in	780, 781, 782, 783
Additional uses	Single fire department connection (plug and chain available separately)
Weight (Lbs.)	9 1/2"
PSI (BAR)	175 (12.1)
Certifications	U.L. Listed

FEMALE SPRING CHECK SNOOT

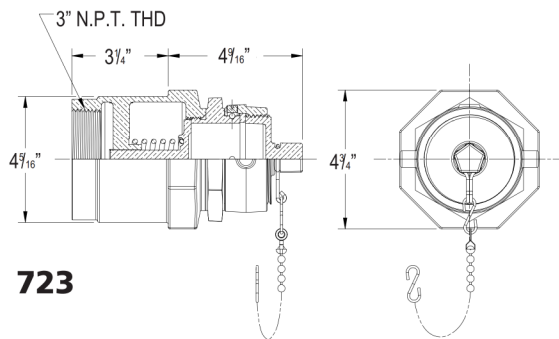

723

Sizes (Inches)	3" F x 2 1/2" or 3" F x 3"
Material/Finish	Cast brass with polished brass exposed parts (optional chrome plating available)
Available with	Plug
Spring check action	Open @ 10 psi (0.69 bar) Flows 250 GPM (946 lpm) @ 12 psi (0.83 bar) Flows 500 GPM (1893 lpm) @ 24 psi (1.65 bar)
Weight (Lbs.)	12 1/4 or 11 3/5

ADDITIONAL INFORMATION

Components rated for 175 psi (12.1 bar), unless otherwise specified.

THREADS

- 710 and 711 are NPT on all connections.
- 720, 721, and 723 feature NPT Inlets, while the outlets are hose thread (NHT). See index T-13 for available optional hose threads.

OTHER PRODUCTS

- Flush Siamese (utilizing the components) are available on page 13-16.
- Caps and plugs are available on page 11-1.
- Escutcheons available on page 13-27.